

**Stratus Tool Technologies, LLC**

2208 Air Park Drive  
Burlington, NC 27215, USA  
Phone: 800-822-3200  
Website: [www.tempestplus.com](http://www.tempestplus.com)

**-MANDATORY-**

**Service Bulletin: SB-001 Rev B**

**Original Date: October 25, 2019**

**Revision Date: June 17, 2021**

**SUBJECT: OIL FILTER ADAPTER GASKETS**

**Applicability:** Continental aircraft engines having any of the following F&M or Stratus oil filter adapters installed in accordance with STCs SE09356SC, SE8409SW & SE10348SC.



**CO-300**  
STC# SE8409SW



**C6LC-L**  
STC# SE09356SC



**C6LC-S**  
STC# SE09356SC



**C6SC**  
STC# SE8409SW

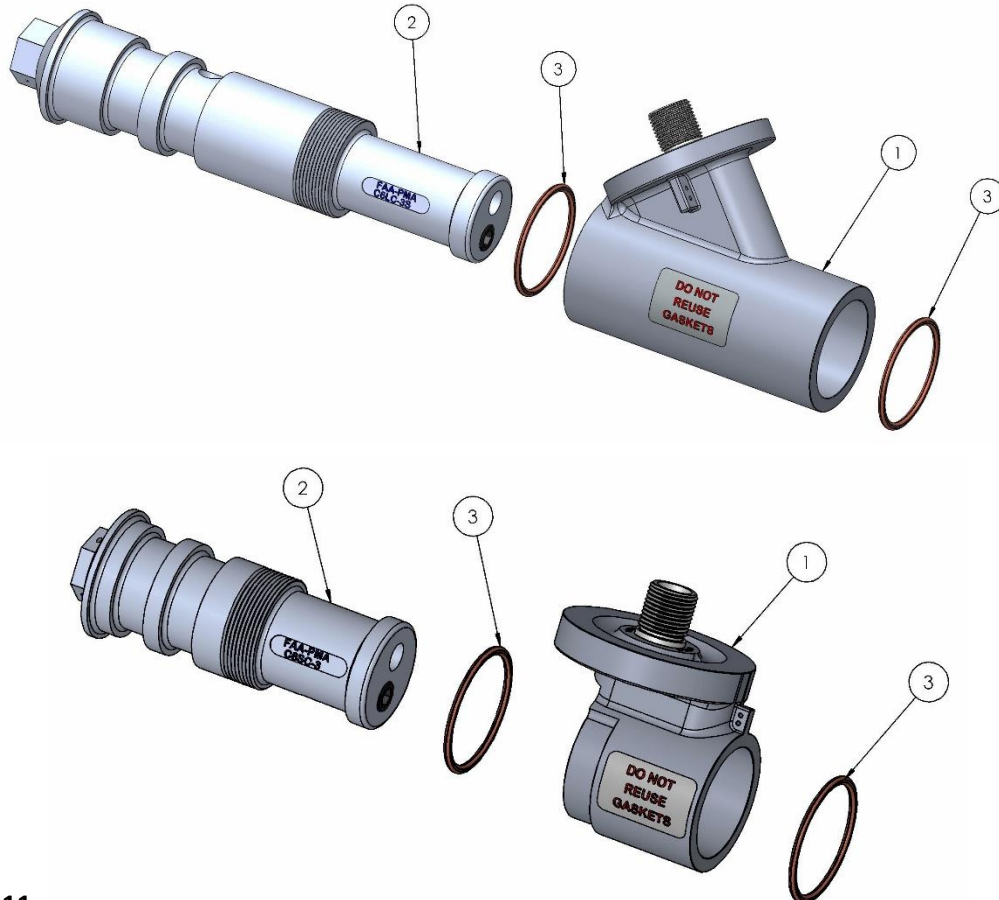


**C6LC-11/15**  
STC# SE10348SC

AIRCRAFT				
<b>CO-300</b> (STC) SE8409SW  Beechcraft Bonanza Beechcraft Debonair Cessna 170, 172 Globe Swift Maule	<b>C6LC-L</b> (STC) SE09356SC  Beechcraft Bonanza Beechcraft Debonair Cessna 205, 206, 207, 210, 310 Grumman Widgeon Meyers Navion Twin Commander	<b>C6LC-S</b> (STC) SE09356SC  Beechcraft Bonanza Beach Baron (Model 55) Beechcraft Debonair Bellanca Viking Cessna 180, 182, 185, 188	<b>C6SC</b> (STC) SE8409SW  Cessna 172 Hawk XP, 175, 336 & 337 Maule Mooney M20-K Piper Seneca II Piper Turbo Arrow III & IV	<b>C6LC-11/15</b> (STC) SE10348SC  Cessna L-19 Bird Dog
ENGINES				
C-125 Series C-145 Series O-300 Series	O-470 Series  (Sand Cast Crankcase Only) IO-470 Series IO-520 Series IO-550 Series TSIO-520 Series	O-470 Series  (Sand Cast Crankcase Only) IO-470 Series IO-520 Series IO-550 Series TSIO-520 Series	GO-300 Series IO-360 Series TSIO-360 Series	O-470-11 O-470-15

ITEM NO.	NOMENCLATURE	QTY.
1	SLEEVE	1
2	SPOOL	1
3	COPPER GASKET*	2

\*AN900-28 copper gaskets are used on all models except model C6LC-11/15 which uses AN900-29 copper gaskets.



### **Reason for Revision**

- a) require the removal of all fiber gaskets and,
- b) add lubrication to spool, sleeve, and top copper gasket during installation of the oil filter adapter.

**Background:** Due to reports of oil leakage at the fiber gasket on some spin-on oil filter adapters (the adapter), the inspections and procedures addressed in this bulletin must be accomplished.

Improper installation, improper maintenance (including, but not limited to failure to identify and eliminate oil leaks), and/or the use of fiber gaskets or re-use of copper gaskets can result in an oil leak and the loss of engine oil. Insufficient engine oil may result in partial or complete loss of engine power.

This bulletin emphasizes the importance of carefully following the Installation Instructions (dated 2/21/2020 or later) and ICA (dated 3/05/2020 or later) and the need for adequate maintenance to ensure that the adapter is not leaking and is properly and securely installed. The most up-to-date, model-specific Installation Instructions and ICAs are readily available at: [TempestPlus.com/products/oil-filter-adapters/](https://www.tempestplus.com/products/oil-filter-adapters/)

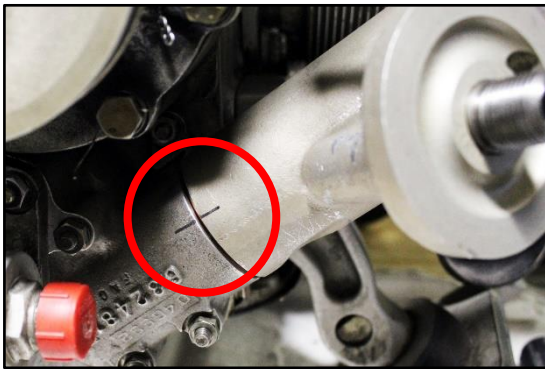
**Compliance Time:** The inspections and instructions described in this bulletin must be accomplished within the next 10 flight hours, annual inspection, or 100-hour inspection, whichever occurs first. If discrepancies are discovered during these inspections, they must be rectified before further flight.

After the inspections and instructions described in Paragraphs 1, 2, 3 (a thru f), 4, 5, 6 and 7 are accomplished, the aircraft may be approved for return to service with respect to the issues addressed by this bulletin.

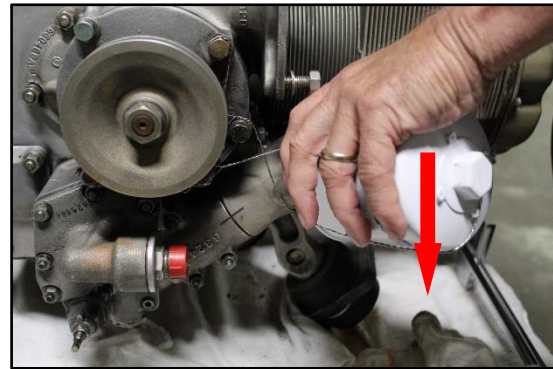
### **Compliance Instructions:**

1. Inspect the oil filter adapter for the presence of a fiber gasket and, if found, proceed directly to Paragraph 4.
2. Using a bright light and mirror, inspect the adapter for leaks, seepage, gasket damage, and security. If any oil leaks or seepage (however slight), copper gasket displacement, adapter looseness, or other defect(s) are discovered, proceed directly to Paragraph 4. Note: Oil and dirt stains on the engine accessory case/oil pump housing adjacent to the adapter may indicate seeping or leaking gaskets.
3. If NO fiber gasket, oil leaks or seepage, however slight, gasket damage, looseness, or other discrepancies are discovered:

- a. Use a fine point felt pen to make a match mark on the sleeve and oil pump housing as shown in Figure 1. While standing beside the aircraft, grasp the oil filter and, using the filter as a lever (or ‘handle’), apply approximately 10 to 20 pounds of force in an attempt to rotate the filter sleeve in a counter-clockwise direction around the spool, see Figure 2. (Note: You are not trying to unscrew the filter itself. You are trying to make the sleeve rotate about the spool). Check the match marks for movement of the sleeve. If ANY displacement of the match marks occurred and/or any movement of the sleeve, the spool, or both are detected, no matter how slight, proceed directly to Paragraph 4.

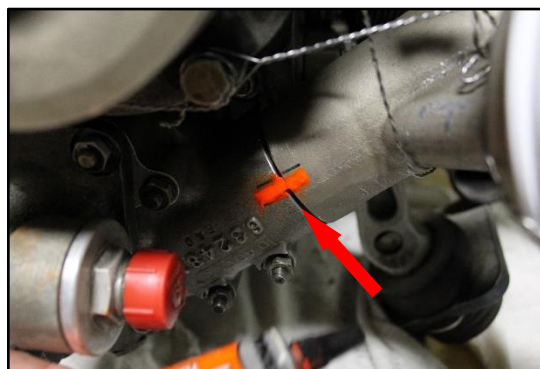


**Figure 1**



**Figure 2**  
(Pushing Down on Filter)

- b. If neither the sleeve or spool moved when tested in accordance with Paragraph 3 (a), apply a bead of Torque Seal (Cross Check ITW PRO Brand or equivalent) across the copper gasket at the sleeve/oil pump housing joining as shown below in Figure 3.

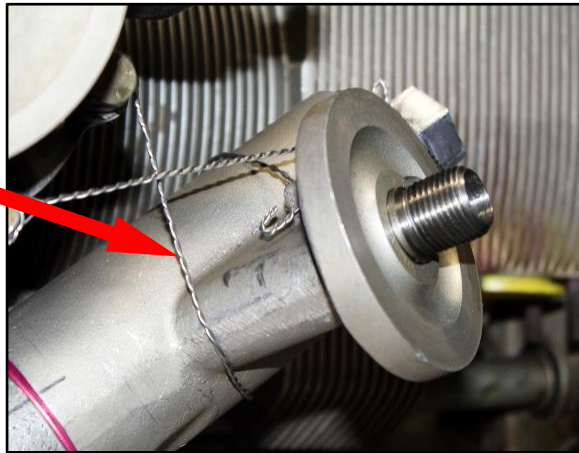


**Figure 3**

- c. Check the safety-wirings (lockwires). They must be tight and run in the correct direction to prevent loosening of the parts they secure. Correct any discrepancies.

- d. If there is no safety-wire securing the sleeve itself against rotation, install safety-wire such that the wire will prevent the sleeve from rotating in a counter-clockwise (loosening) direction, see Figure 4. Secure the safety-wire to a suitable location **on the engine**. Do not secure any safety-wire from the adapter to the airframe.

**SAFETY- WIRE**  
securing the body itself  
against CCW rotation



**Figure 4**

- e. If, during ANY inspection, the Torque Seal applied to the adapter is broken or missing, thoroughly inspect and investigate the oil filter adapter for **leaks, seepage, bulging, and security**. **If defects are found, make necessary repairs prior to approving the aircraft for return to service. ALWAYS INSTALL NEW COPPER GASKETS ANY TIME THE ADAPTER IS REMOVED, ADJUSTED, LOOSENED, OR REPAIRED. NEVER ATTEMPT TO CORRECT AN ADAPTER OIL LEAK OR LOOSE SLEEVE BY TIGHTENING THE SPOOL ON USED GASKETS.**
- f. Replace broken or missing Tamper Seal before approving the aircraft for return to service.
4. **Remove the adapter from the engine.** Cut and remove the safety-wire as necessary. Then, unscrew the spool from the engine oil pump housing and remove the adapter. Tag the aircraft “OUT OF SERVICE – DO NOT FLY” until appropriate repairs are accomplished.
5. Reinstall the oil filter adapter in accordance with the model-specific Installation Instructions (dated 2/21/2020 or later) and ICA (dated 3/05/2020 or later) applicable to your model oil filter adapter. It is imperative that the instructions in the Installation Instructions and ICA be followed. **Note: Stratus Tool Technologies has discontinued the use of fiber gaskets. Only copper gaskets are approved for initial installation or reinstallation of F&M or Stratus Tool Technologies oil filter adapters.**



6. The following information is provided to assist you in carrying out the instructions in the Installation Instructions, ICA, and this Service Bulletin.

In conjunction with the latest FAA approved installation instructions (dated 2/21/2020 or later) and FAA accepted ICA (dated 3/05/2020 or later), the following inspection and verification steps are recommended:

Occurrence	Recommended Action
Each oil change	<p>When inspecting the oil filter adapter for oil seepage per step 4.a of Stratus Tool Technologies, LLC ICA ST001, also perform the following inspection to verify gasket integrity and installed location:</p> <p>a. Inspect the adapter installation for signs of oil leakage, displaced gaskets, looseness, damage or other anomalies. If any defects are found, replace both gaskets with new copper gaskets prior to further flight in accordance with the applicable Stratus Tool Technologies installation instructions dated 2/21/2020 or later. <b>DO NOT INSTALL OR REUSE A FIBER GASKET</b> in any F&amp;M or Stratus oil filter adapter.</p>
Each 100-hour or annual inspection	
Any time the adapter is removed or installed	
Following any oil filter installation	<p>Check and verify per step 4.d of Stratus Tool Technologies, LLC ICA ST001 “that the sleeve will not rotate around the oil transfer spool when approximately 10 to 20 pounds of force is applied to an oil filter mounted on the adapter in a manner that would tend to rotate the sleeve around the spool...”</p> <p>If the sleeve rotates around the spool, replace both copper gaskets and reinstall the adapter in accordance with the current applicable Stratus Tool Technologies installation instructions.</p>

**NOTE: Whenever tightening the spool to 65 ft-lbs of torque, ensure the gaskets and sleeve do not rotate around the spool, as damage may occur to the gaskets. If this occurs, replace both gaskets and reinstall per the appropriate installation instructions.**

Thoroughly clean the threads of the oil pump housing, see Figure 5. (You may need to dip or siphon excess oil from the oil pump housing to facilitate cleaning the oil pump housing threads). Lubricate the threads with clean engine oil.

Lubricate the large diameters and under the flange of the spool with clean engine oil as shown in Figure 6.

Lubricate the inside diameter and top surface of the sleeve with clean engine oil as shown in Figure 7.



**Figure 5**



**Figure 6**



**Figure 7**

Lubricate one copper gasket with engine oil and install it onto the spool with the split side of the gasket turned away from the spool's flange, see Figure 8.

Slide the spool through the sleeve's bore and place the second copper gasket on the spool with the split side of the gasket away from the sleeve, see Figure 9.



**Figure 8**



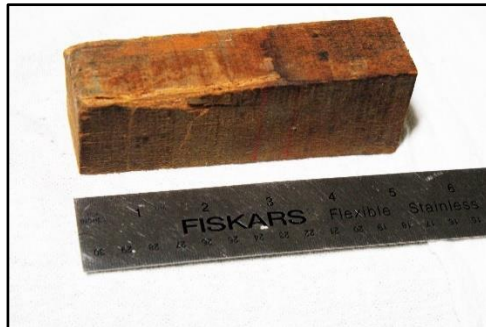
**Figure 9**

Thread the spool into the oil pump housing, when the adapter is ready to be tightened, use a fine point felt pen to make a match mark on the sleeve and oil pump housing as shown in Figure 10.



**Figure 10**

Fabricate a wooden block/wedge that will fit snugly between the oil filter mount flange and an adjacent structurally sound part of the engine or airframe that is competent to resist the turning forces encountered when tightening the spool. Place the block so that as the spool is tightened, the sleeve cannot rotate with the spool. See the exemplar arrangement in Figures 11 and 12.



**Figure 11**



**Figure 12**

Note: Because the oil filter adapters are used on many different aircraft, the block/wedge arrangement will be different in different aircraft.

With the block in place, tighten the spool to 65 ft-lbs torque. If the match marks misalign by more than 1/32 inch after tightening the spool, i.e., the sleeve has moved relative to the oil pump housing, remove the adapter assembly from the engine as previously described. Replace both gaskets with new copper gaskets, relube the sleeve, spool, and top gasket with engine oil as shown in figures 6 and 7 and reinstall the adapter in accordance with the instructions contained in the Installation Instructions and ICA applicable to your model adapter.

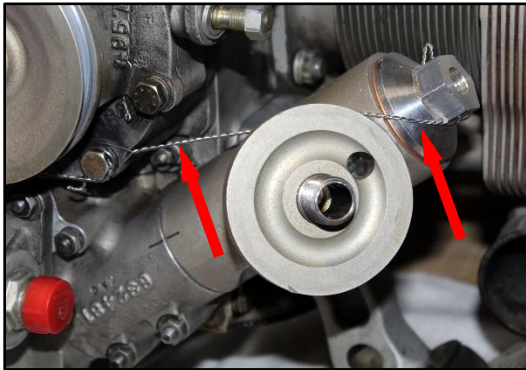


When the installation is successful, i.e., the match marks are aligned within limits, and the spool is tightened to 65 ft-lbs torque, safety-wire the:

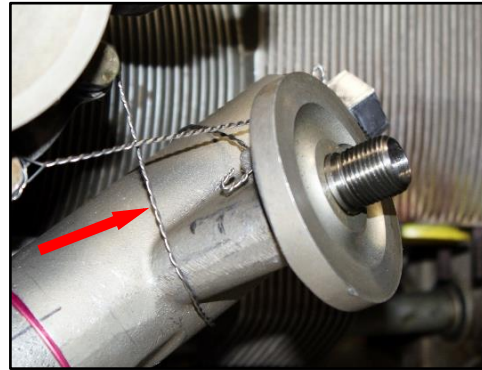
- a. spool to the engine (Figure 13) and,
- b. the sleeve to the engine. Wrap the wire around the sleeve in such a manner that the sleeve cannot turn counter-clockwise, see Figure 14.

Install the oil filter. Tighten it to the torque recommended by the filter manufacturer. Safety-wire the filter to the safety-wire tab on the sleeve, see Figure 15.

*Do not secure any safety-wire from the filter adapter or filter to the airframe.*



**Figure 13**

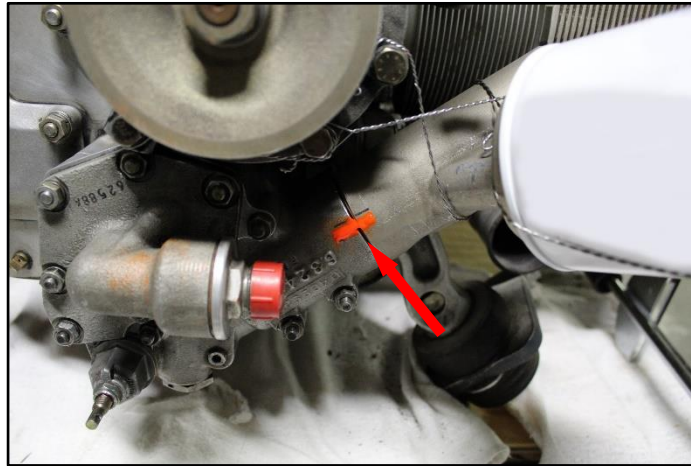


**Figure 14**



**Figure 15**

When the adapter is successfully installed, clean any residual oil from the adapter and apply a bead of Tamper Seal from the oil pump housing across the copper gasket and onto the sleeve as shown in Figure 16.



**Figure 16**

7. PRIOR TO APPROVAL FOR RETURN TO SERVICE:

- a. Reinstall any airframe or engine parts removed in accordance with the airframe or engine manufacturer's instructions.
- b. Check and, if necessary, replenish the engine oil. *The filter may hold up to about one quart of oil, so check the engine oil after the leak check engine run.*
- c. Perform an engine run to check for oil leaks. Run the engine for at least 5 minutes. Stop the engine and inspect the adapter installation for leaks.
- d. Make a detailed logbook entry referencing this Service Bulletin Number SB-001 Rev B dated 5/26/21, or later revision, to memorialize the adapter installation inspections and re-installation, and/or any other work accomplished while complying with this service bulletin.



For additional information regarding this Service Bulletin, contact:

Stratus Tool Technologies, LLC

2208 Air Park Drive

Burlington, NC 27215

800-822-3200

For the most up-to-date, model-specific Installation Instructions and Instructions for Continued Airworthiness, please visit [TempestPlus.com/products/oil-filter-adapters/](http://TempestPlus.com/products/oil-filter-adapters/)

**Safety First:** Stratus Tool Technologies, LLC is a customer-service orientated company committed to technical innovation in pursuit of aviation safety. While Stratus Tool Technologies has no authority to compel aircraft owners and/or operators to act responsibly and take prudent action to ensure their own safety and the safety of others, Stratus Tool Technologies believes that compliance with this MANDATORY service bulletin is important and will help ensure better maintained and better performing products.